

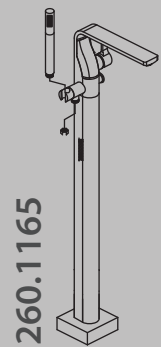

Installation Manual

Floor Mount Tub Filler

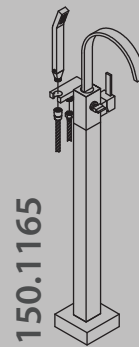
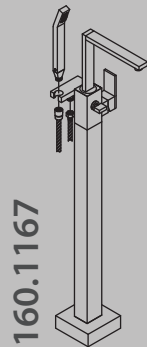
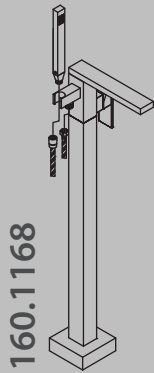

BEFORE YOU BEGIN

- You must observe all local plumbing laws and codes.
- Do not install this item if it does not meet local plumbing codes.
- Shut off the main water supply.

TABLE OF CONTENTS

• Operating Specifications	1
• Valve Installation And Tolerance	
• Cut-Out Dimensions	1
• Rough In Specification	2
• Faucet Placement	3
• Securing Valve To The Floor	4
• Valve Position With Respect To The Tub	5
• Using The Water Plugs	5
• Flushing The Valve	5
• Installing The Trim	6
• Replacing The Cartridge	8
• Replacing The Diverter Mechanism	9
• Cartridge Maintenance	10

NOTICE TO HOMEOWNER

- We recommend that this product is installed by a qualified professional plumber.
- Please check this product immediately to ensure that it has not been damaged and is complete. Before installation, please make sure this product is the correct model and you have all the parts required for installation and use.
- Please flush the water system to ensure that no metal swarf, solder, and other impurities can enter the product.
- Turn off water supply before commencing work.
- Please read these instructions carefully and retain for future reference.

OPERATING SPECIFICATIONS

WATER TEMPERATURE



This product is to be used with water at a temperature range of 40°F - 120°F ONLY!

WATER PRESSURE



This product is to be used with a water pressure range of 15 PSI to 80 PSI ONLY

If water pressure is greater than 80 PSI install a pressure reducing valve (PRV)

This valve meets or exceeds ANSI A112.18.1 and ASSE 1016

This product is certified by IAPMO

CUT OUT DIMENSIONS

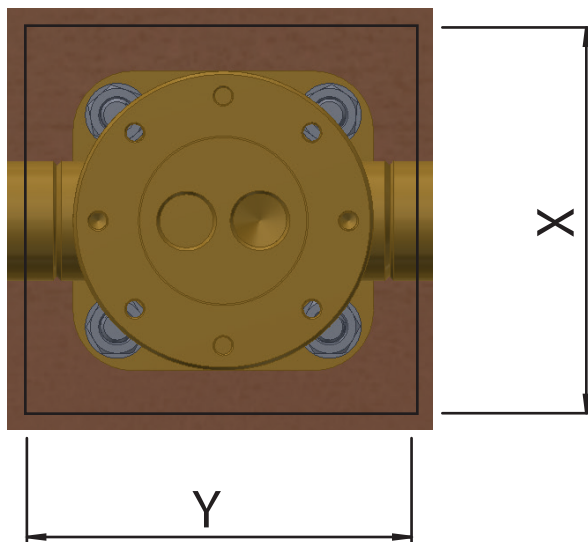

FLOOR CUT-OUT DIMENSIONS

Isenberg's floor mount valves come with escutcheon plates to cover the hole in the tile / floor.

It is essential to review the cut-out dimensions mentioned here so that the cut-out in the floor is not accidentally bigger than the size of the escutcheon plate.

Cut Out Dimensions
From Center Point of Valve:

X = 100 mm / 3.93"

Y = 100 mm / 3.93"

ROUGH IN SPECIFICATION

30mm [1.181"]
20mm [0.787"]

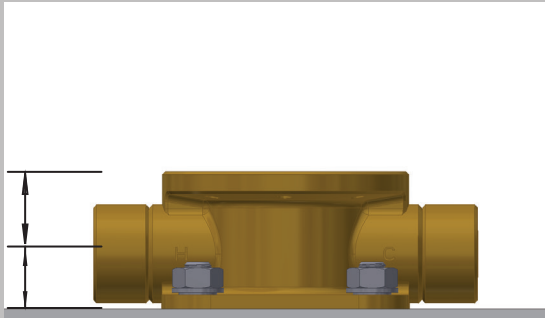

The distance between the center point of valve inlet (hot, cold) to the floor and top of the valve is seen on the right.

Level the valve before securing into the floor. Ensure valve is straight and do not install at an angle.

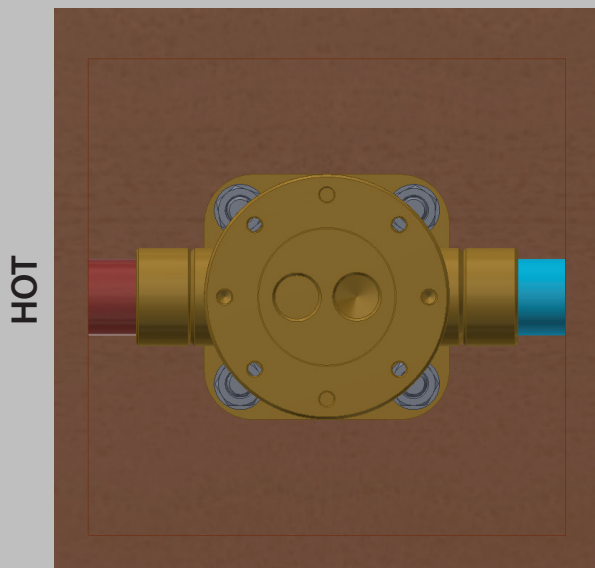

The connections for Hot & Cold water supply lines are shown on the left.

FAUCET PLACEMENT



SECURING VALVE TO THE FLOOR

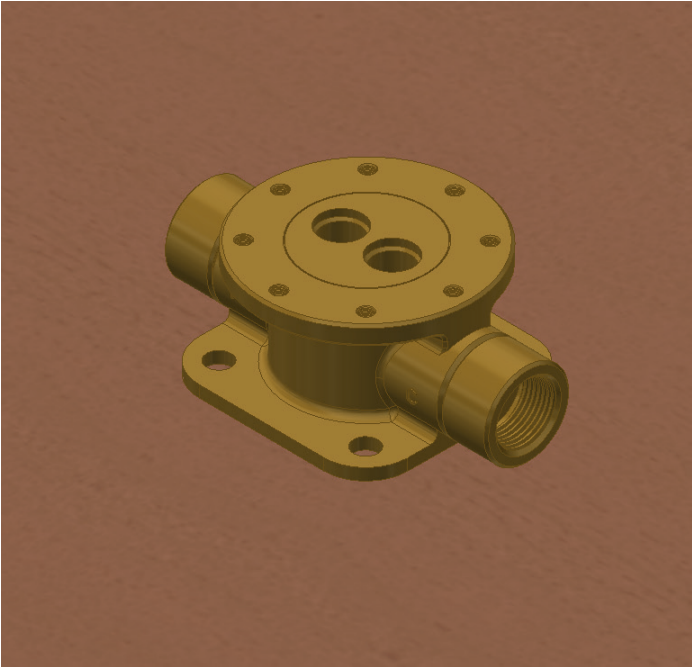

Mark holes for floor bolt installation

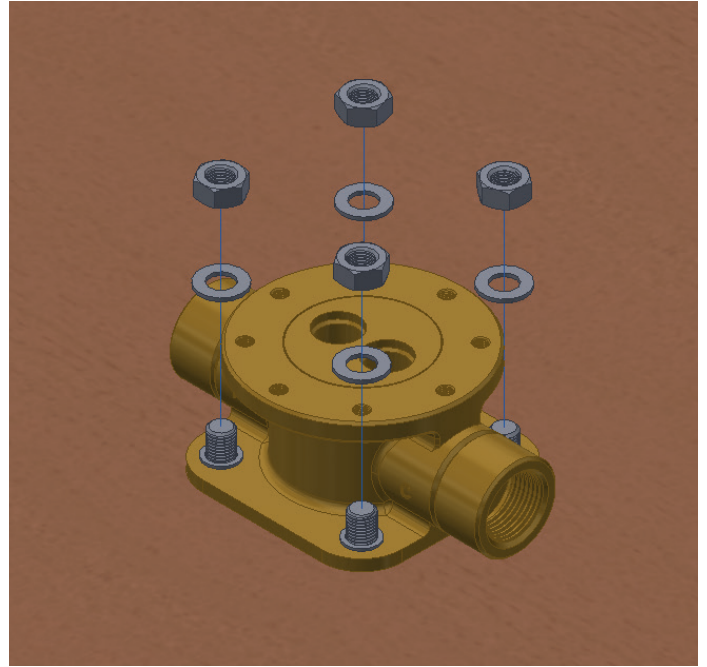

Install valve using floor bolts

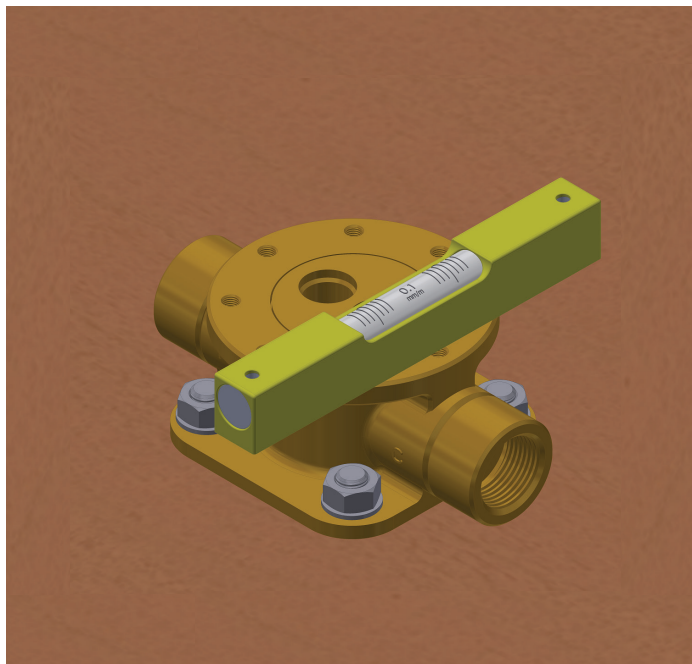

Ensure valve is perfectly level

VALVE POSITION WITH RESPECT TO TUB

This illustration highlights recommended placement of the valve with respect to the tub.

Note:
The Trim Piece
can be rotated 360°



USING THE WATER PLUGS

The supplied plugs should be used to block water output during installation.

Insert plugs and use connector and screws to hold in place.

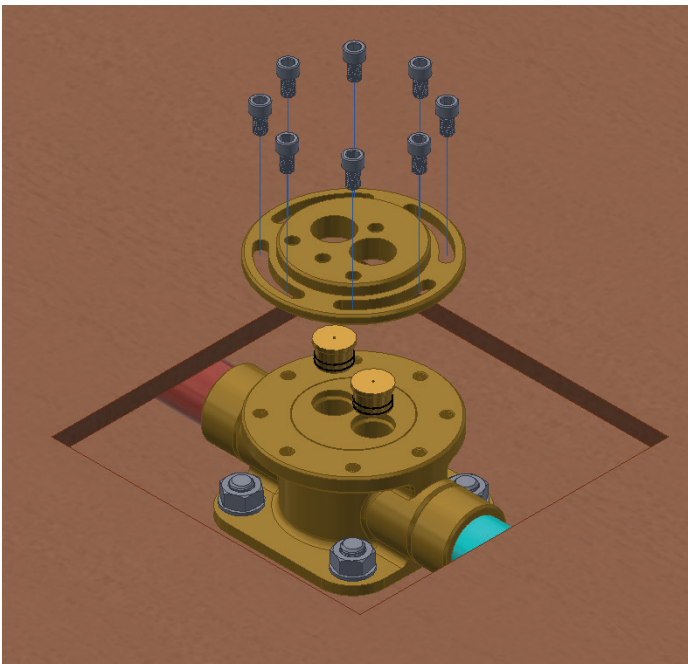

INSTALLING THE TRIM - SIZE AND SHAPE MAY VARY - ILLUSTRATION ONLY

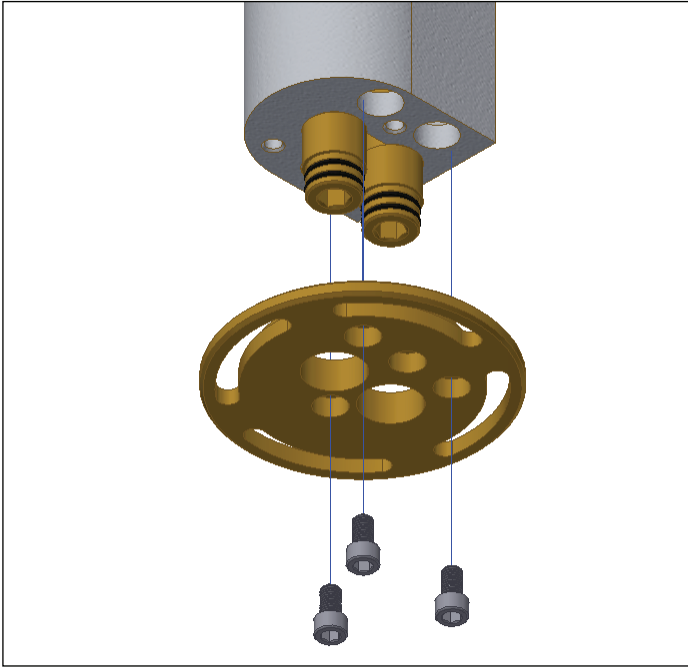

Install connector and tighten screws on bottom of trim

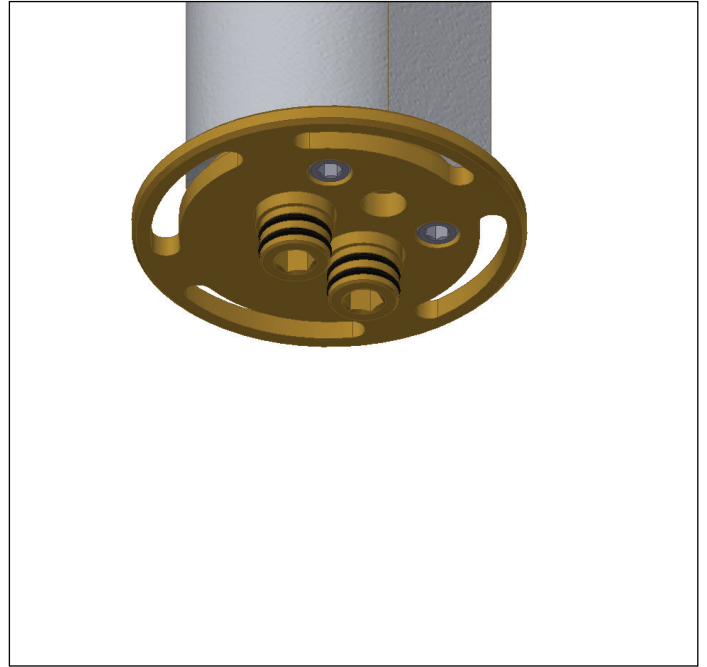

Ensure double o-rings are undamaged and greased

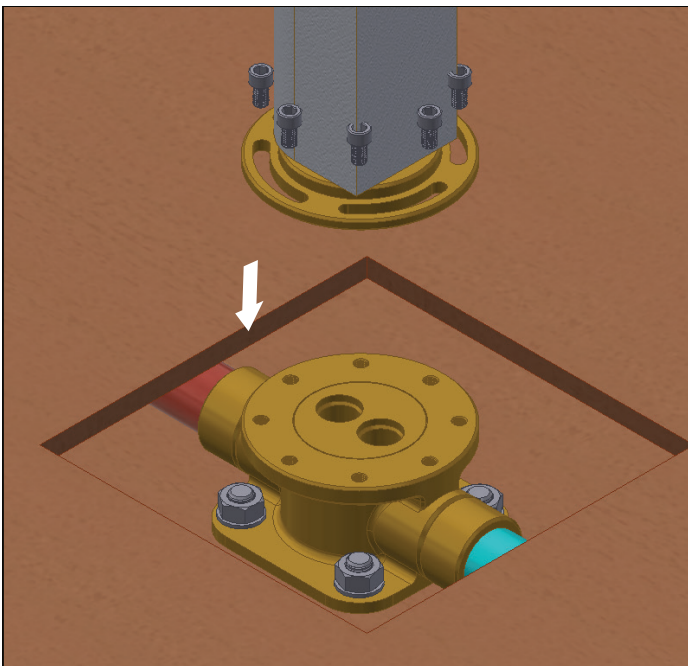

Insert trim onto valve. Tighten screws

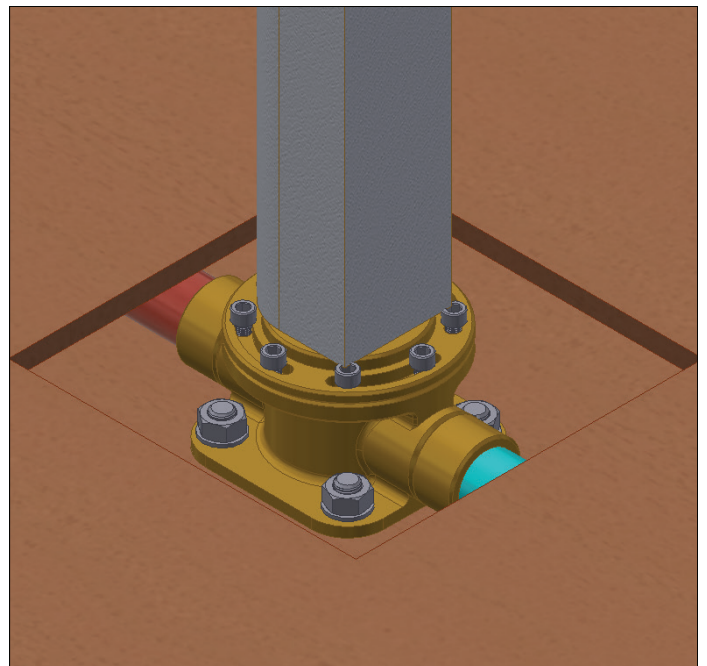

Ensure that all screws are tight

INSTALLING THE TRIM - SIZE AND SHAPE MAY VARY - ILLUSTRATION ONLY

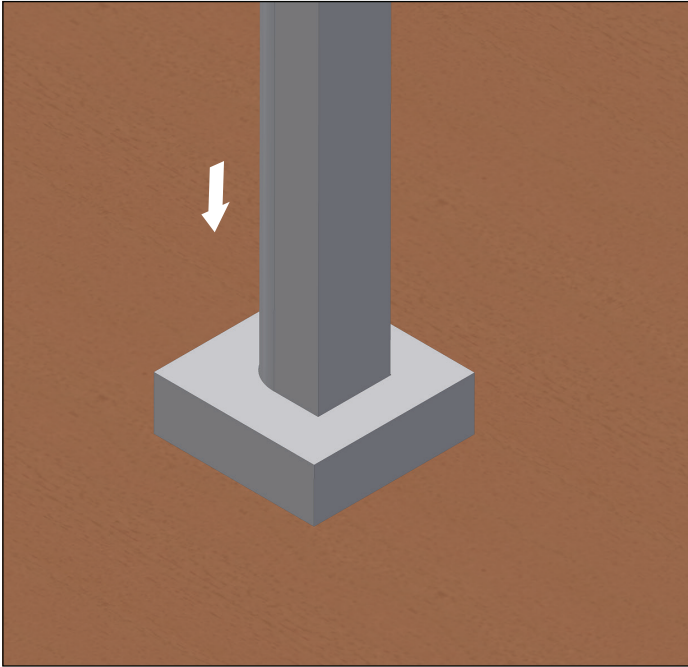

Push down floor cover



Screw on hand held and hose

REPLACING THE CARTRIDGE



In order to remove or service the cartridge follow the procedure below:

- 1) Remove handle. Cover button and hex screw on handle will need to be removed.
- 2) Unscrew cartridge bezel and retaining nut.
- 3) Pull out cartridge

REPLACING THE DIVERTER MECHANISM

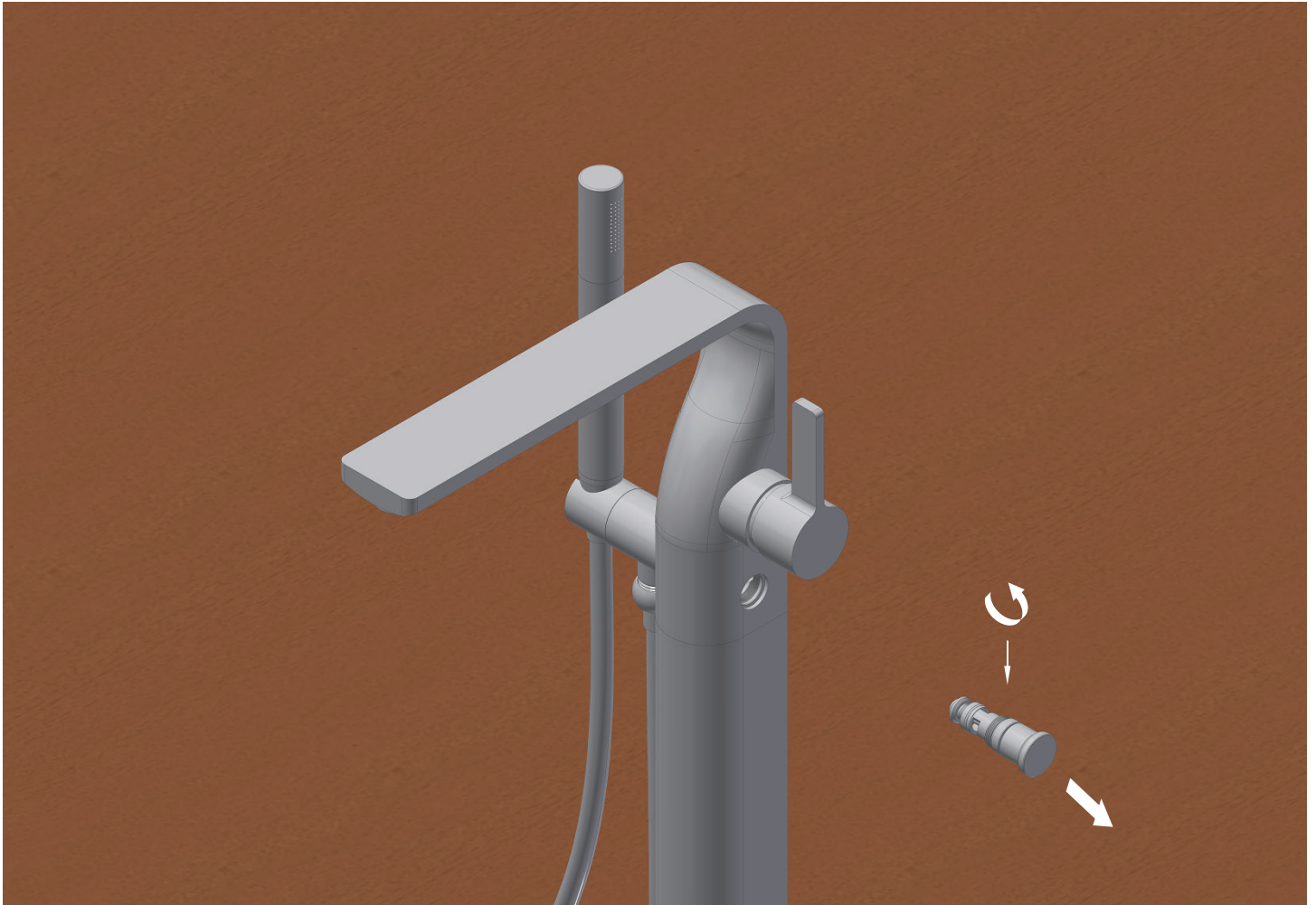

1) Remove diverter mechanism by un-screwing and pulling out

CARTRIDGE CLEANING & MAINTENANCE

